

ABSOLUTE Inside Caliper

SERIES 573, 536 — Knife-edge/Inside Groove/Point Jaw Type

FEATURES

- Specially designed for inside measurements in hard-to-reach places.
- With SPC data output. (Series 573)
- Supplied in fitted plastic case.
18" / 450mm and 24" / 600mm supplied in wooden case.

Knife-edge type



Inside groove type



Point jaw type

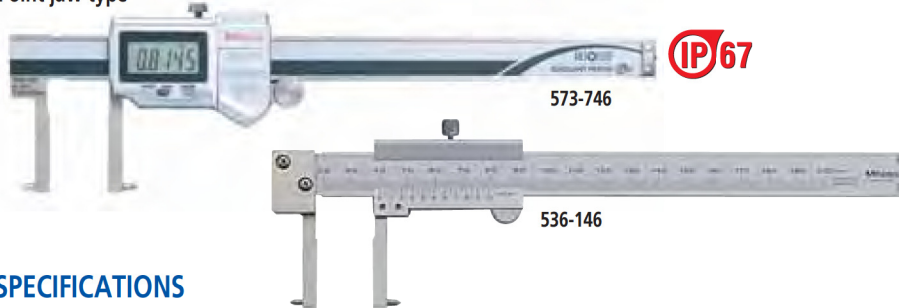

SPECIFICATIONS

Metric Digital model

Range	Order No.	Accuracy	Remarks	Mass (g)
10 - 200mm	573-642	±0.05mm	Knife-edge type, Measurable min. hole diameter: ø10mm	227
10 - 160mm	573-645	±0.05mm	Inside groove type, Measurable min. hole diameter: ø10mm	147
20 - 170mm	573-646	±0.03mm	Point jaw type, Measurable min. hole diameter: ø20mm	157

Inch/Metric Digital model

Range	Order No.	Accuracy	Remarks	Mass (g)
.4" - 8" / 10-200mm	573-742	±.002"	Knife-edge type, Measurable min. hole diameter: ø.4"	227
.4" - 6" / 10-150mm	573-745	±.002"	Inside groove type, Measurable min. hole diameter: ø.4"	147
.8" - 6" / 20-150mm	573-746	±.0015"	Point jaw type, Measurable min. hole diameter: ø.8"	157

Metric

Range	Order No.	Accuracy	Remarks	Mass (g)
10 - 200mm	536-142	±0.12mm	Knife-edge type, Measurable min. hole diameter: ø10mm	210
10 - 150mm	536-145	±0.05mm	Inside groove type, Measurable min. hole diameter: ø10mm	130
20 - 150mm	536-146	±0.05mm	Point jaw type, Measurable min. hole diameter: ø20mm	140
30 - 300mm	536-147	±0.08mm	Point jaw type, Measurable min. hole diameter: ø30mm	370
70 - 450mm	536-148	±0.10mm	Point jaw type, Measurable min. hole diameter: ø70mm	1,250
70 - 600mm	536-149	±0.12mm	Point jaw type, Measurable min. hole diameter: ø70mm	1,430



Technical Data

Accuracy: Refer to the list of specifications.
 Resolution*: .0005"/0.01mm / 0.01mm
 Graduation***: 0.05mm
 Display*: LCD
 Length standard*: ABSOLUTE electrostatic capacitance type linear encoder
 Max. response speed*: Unlimited
 Battery*: SR44 (1 pc.), **938882**
 Battery life*: Approx. 3.5 years under normal use
 *Digital models **Analog models

Function of Digital Model

Origin-set, Zero-setting, Power On/Off, Data output, inch/mm conversion (on inch/metric models only)
 Alarm: Low voltage, Counting value composition error

Optional Accessories for Digital Model

- 05CZA624:** SPC cable with data switch (40" / 1m)
- 05CZA625:** SPC cable with data switch (80" / 2m)

Knife-edge type

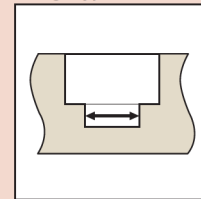

Inside groove type

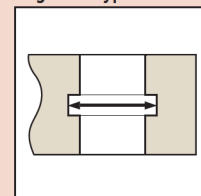

Point jaw type

